

 **NECTA**

SCEGLIERE LA BEV

KOBALTO

| | | | | |
|-----------------|--------------------|--------------------------|--|-------------------|
| ESPRESSO | CAFFÈ LUNGO | PRESELEZIONE DECA | ORZO | ORZO LUNGO |
| ESPRESSO | CAFFÈ LUNGO | CIOCCOLATO |  | STOP |

All you could wish for



The pleasure of a professionally prepared espresso coffee, aromatic steaming chocolate or a delicious frothy cappuccino is just the push of a button away. The new Kobalto, a dispenser of high quality hot drinks, can fulfill all your beverage wishes.

Necta, a leading trademark well-known and appreciated all over the world, has used all its technical expertise and years of beverage experience to develop the Kobalto. It is available in several versions and can offer a combination of technologies: bean to cup, espresso, instant, and automatic milk steaming as well as a wide range of ingredients such as fresh beans, soluble coffee, fresh or powdered milk, or chocolate.

Due to its flexibility and wide product range, the Kobalto is ideally suited to meet all the requirements of the Out of Home market. Modern Italian styling, combined with compact size and simple user interface make it a wide-ranging machine with broad appeal that can be easily positioned in any location.



Excellent drinks

The Kobalto exploits all Necta's technologies to offer beautifully presented excellent tasting creamy drinks, rich in aroma, and capable of satisfying the most demanding palates.

Espresso: the patented and well established Necta Espresso Brewer makes an authentic espresso and thereby provides the perfect base for all the popular bean to cup drinks. The consistent quality of the grinding of beans and accurate metering of water at just the right pressure ensure the creation of a drink that is characterised by a strong rich aroma.

Soluble: by using new-concept mixers, the Kobalto adds a welcomed cr me to soluble coffee, cappuccino or chocolate.

Ease of use

The Kobalto is an extremely user-friendly machine, whether behind the bar for staff (waiter, operator or barman), or in self-service mode for the end customer.

Just press a button to dispense any kind of drink. For perfect cappuccinos or white coffees, there is the choice of an automatic milk steamer for fresh milk or an internal mixer for powdered milk.

The Kobalto has a large selection panel that is easy to read and use. Each button has a blue light that guides the user through the selection process, ensuring quick and easy operation. Customised messages can also appear on the large electronic display placed just above the selection buttons.

The retractable dispense head has been designed to efficiently accommodate both small and large cups.

A rich and complete menu

The Kobalto can offer a wide range of drinks. Between 8 and 16 selections can be customised – using a wide range of products: bean, soluble coffee, fresh or powdered milk, and chocolate. In the espresso version, the Kobalto can have 1 or 2 coffee bean hoppers and a variety of soluble products combined with an automatic milk steamer.

Simple cleaning and servicing operations

The Kobalto is designed to allow even first time users simple and easy access to all components that require regular cleaning. The wide opening of the door provides instant access to the Espresso Brewer and to the mixers of the soluble products. All these components can be easily removed to aid internal cleaning. The coffee waste containers can be simply accessed through the door behind the dispensing area.



The Kobalto is available in the following versions

ES + 2 IN

1 ES Brewer - 1 or 2 coffee bean hoppers - 2 instant canisters - 1 mixer - 1 dispensing point - self-service or back of bar mode

Drinks delivered:

made with coffee beans, soluble coffee, fresh or powdered milk and chocolate

americano
café latte
cappuccino
café au lait
espresso
hot chocolate
hot water

Hot water for tea is available at the same delivery point as the other drinks.

Hourly output:

Approx. 100 cups per hour
30 litres of hot water

Ingredients capacity:

Coffee beans: 1.2 kg
Chocolate: 2 x 1.7 kg

Weight:

78 kg



ES + 3 IN

1 ES Brewer - 1 coffee bean hopper - 3 instant canisters - 2 mixers - 1 dispensing point - self-service or back of bar mode

Drinks delivered:

made with coffee beans, soluble coffee, powdered milk and chocolate

americano
café au lait
cappuccino
espresso
café mocha
hot chocolate
hot water

Hot water for tea is available at the same delivery point as the other drinks.

Hourly output:

Approx. 100 cups per hour
80 litres of hot water

Ingredients capacity:

Coffee beans: 1.2 kg
Soluble Coffee: 0.5 kg
Whitener: 0.7 kg
Chocolate: 1.7 kg

Weight:

84 kg



4 IN

4 IN canisters - 3 mixers - 1 dispensing point - self-service and back of bar mode

Drinks delivered:

americano
café au lait
cappuccino
café latte
hot chocolate
café mocha
hot water

Hourly output:

Approx. 100 cups per hour
80 litres of hot water

Ingredients capacity:

Soluble coffee: 2 x 0.65 kg
Powdered milk: 0.7 kg
Chocolate: 3.1 kg

Weight:

59 kg



Accessories:

- Cup-warmer for side or top of the machine
- Base cabinet
- Water self-feeding kit (20 litres)
- Plinth to increase the height of the cup station and allow the use of carafes up to 300 mm (Kobalto IN)
- Cup station extension (Kobalto IN)

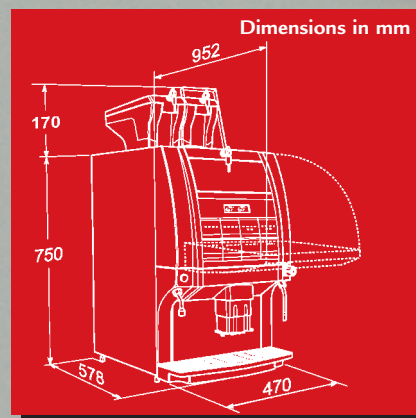

Example of Instant Version
(indicative)



Example of Espresso Version
(indicative)





A matter of experience.

N&W has been developing and producing automatic beverage dispensers for the Out-of-Home and Catering sectors for many years and supplies over 100 countries. This market leadership has been achieved and maintained by investing heavily in research and development and is the result of many years of technical and manufacturing experience, combined with a passion for innovation and design.

N&W products are developed and produced using processes approved to two internationally recognised standards, one for quality - UNI EN ISO 9001:2000 - Valbrembo, Mozzo, Odense and Bilston sites, and one for the environment - UNI EN ISO 14001 - Valbrembo and Mozzo sites.

N&W is committed to providing the market with first-class high quality products and the quality certification of all its plants underlines this significant commitment. With regard to the environment, N&W has always paid great attention to the environmental impact of its products and processes and continuously strives to keep this to a minimum.

A further important certification achieved by N&W is supplied by IMQ, Istituto Italiano del Marchio di Qualità (Italian Quality Trademark Institute). This certification assures all N&W products meet the home appliance safety standards as well as the safety standards for commercial dispensers.



N&W GLOBAL VENDING Ltd
P.O. Box 25, Dudley Street
Bilston
West Midlands WV14 0LF
Ph. +44 (0)1902 355 000
Fax +44 (0)1902 402 272

www.nwglobalvending.co.uk

N&W GLOBAL VENDING S.p.A.
Via Roma 24 - 24030 Valbrembo (BG)
Ph. +39 035 606 111
Fax +39 035 606 463



N&W